

USER MANUAL

BSB-ESS-51.2V-200AH-Luxury



BIGBANG SOLAR COMPANY LIMITED

contents

1.TECHNICAL DATA	01
2.PRODUCT OVERVIEW	03
2.1 brief introduction	03
2.2 Interface Introduction	04
2.2.1 Switch ON/OFF	04
2.2.2 Interface Introduction	05
2.2.3 Explanation of LED light changes	06
2.2.4 Power indicator light description	06
3.INSTALLATION GUIDE	07
3.1 Checking Before Installation	07
3.1.1 Checking Outer Packing Materials	07
3.1.2 Cheeking Deliverables	07
3.2 Tools	09
3.3 Installation requirements	10
3.3.1 Installation environment requirements	10
3.3.2 Installation carrier requirements	10
4.MAINTENANCE	13
4.1 Recharge Requirements During Normal Storage	13
4.2 Recharge Requirements When Over Discharged	14

01

TECHNICAL DATA

note

Operating current derating according to cell

Voltage and battery temperature

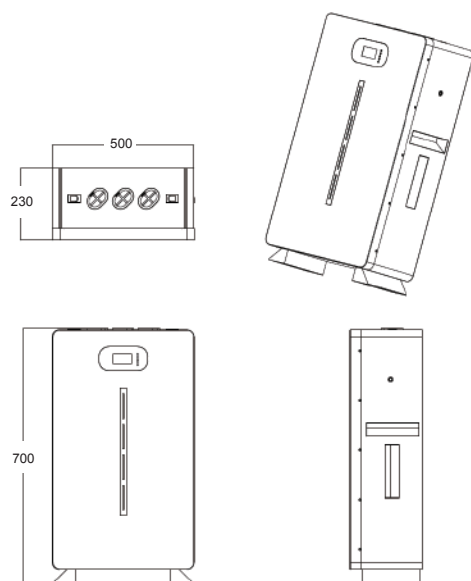

Power supply model	BSB-ESS-51.2V-200Ah-Luxury
Nominal voltage	51.2V
Nominal capacity	200Ah/10.24kWh
Charging protection voltage	56.8V
Discharge protection voltage	46.4V
Recommended charging current	≤100A
Maximum charging current	100A
Recommended discharge current	≤100A
Maximum discharge current	100A
Battery cycle life	≥6000 (25°C±2°C, 0.5C charge/discharge, DOD≥80%)
Communication mode	RS485/RS232/CAN
Charging temperature	0-55 °C
Operating temperature	-20-55 °C
Battery weight	≈100Kg
Battery size	500*250*700mm (adjustable)
certification	MSDS、UN38.3
Adaptable inverter (can be customized)	485: PYLONTECH、TOPBAND、GROWATT、LUXPOWER、CPSYPOWER、SRNE、Felicity solar、ANC、Shark TopSu CAN: PYLONTECH、Deye、TOPBAND、GROWATT、LUXPOWER、GOODWE、SHOUHANG、INVT、MEGAREVO、GINLONG、Afore、SOROUPS、CFAT、BEITT、MUST、SMA、SACOLAR、TBB

*Can be customized according to the needs, the final interpretation of this product is owned by the company, subject to change without prior notice

02

PRODUCT OVERVIEW

2.1 Brief introduction

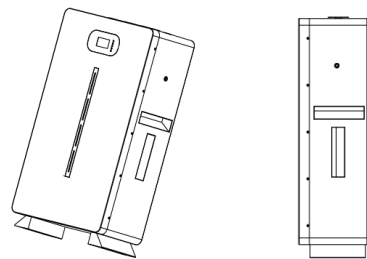

Product overview

This product is made of Iron(III) phosphate lithium battery cells in series, It is an advanced environmentally friendly household energy storage system, Fashionable design with high energy. long service life, Easy to install and expand. With rich battery management experience and advanced Energy storage, BSB-ESS-51.2V-280Ah-Luxury Equipped with advanced intelligent Battery management system, The system adopts a modular design, integrating functions such as collection, monitoring, management, and communication, Achieved high-precision single voltage (10mv) / Current collection , Can simultaneously monitor the environment , Temperature changes of battery cells and main heating devices. Extending the lifespan of battery

2.2 Interface Introduction

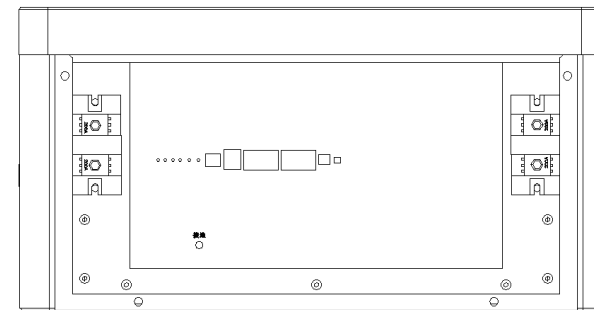

2.2.1 Switch ON/OFF

1.SWITCH ON

When used, Connect the load or inverter end wires to the output end of the battery pack first B+/B-, After confirming the wiring is completed, Turn on the power switch of the battery pack, The battery pack begins to supply power to the load for use.

2.SWITCH OFF

After use, Turn off the load and inverter switches first, Then turn off the battery pack switch

2.2.2 Interface Introduction

System state	Running state	RUN	ALM	Battery indicator LED				illustrate
Shutdown	Hibernate	off	off	off	off	off	off	All off
Standby	Normal	flash1	off	Display based on battery level				Position in readiness
	Alarm	flash1	flash3	Display based on battery level				Example: Module undervoltage
Charge	Normal	on	off	off	off	off	flash2	0~25% charge
		on	off	off	off	flash2	on	25%~50% charge
		on	off	off	flash2	on	on	50%~75% charge
		on	off	flash2	on	on	on	75%~100% charge
	on	off	on	on	on	on	Charged	
	Alarm	on	flash3	Display based on Normal charging level				/
	Protect	off	on	Display based on Normal charging level				/
Discharge	Normal	flash3	off	on	on	on	on	100%~75% discharge
		flash3	off	off	on	on	on	75%~50% discharge
		flash3	off	off	off	on	on	50%~25% discharge
		flash3	off	off	off	off	on	25%~0% discharge
	Alarm	flash3	flash3	Display based on Normal discharge capacity				/
	Overcurrent, short circuit, reverse connection, failure protection, etc	off	on	off	off	off	off	Stop charging and discharging
Temperature	Normal	Normal indication based on status						/
	Charge Alarm	on	flash3	According to the charging level indicator				Maximum LED flashing 2
	Discharge Alarm	flash3	flash3	According to the charging level indicator				According to the constant light indication of the battery level
	Protect	off	on	off	off	off	off	/

2.2.3 Explanation of LED light changes

State	Charge				Discharge				
Capacity indicator light	L4	L3	L2	L1	L4	L3	L2	L1	
Electricity consumption (%)	0~25%	off	off	off	flash2	off	off	off	on
	25~50%	off	off	flash2	on	off	off	on	on
	50~75%	off	flash2	on	on	off	on	on	on
	≥75%	flash2	on	on	on	on	on	on	on
Operation indicator	on				flash				

2.2.4 Power indicator light description

Flashing mode	ON	OFF
flash 1	0.25s	3.75s
flash 2	0.5s	0.5s
flash 3	0.5s	1.5s

03

INSTALLATION GUIDE

-In stallation flow chart-

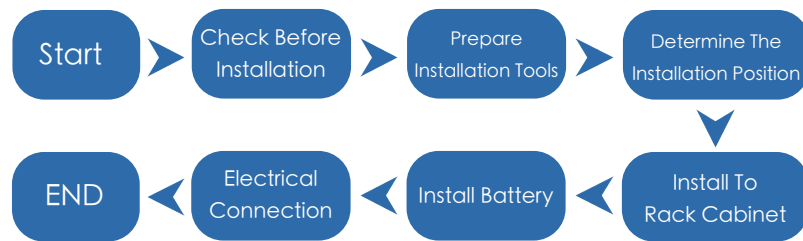

3.1 Checking Before Installation

3.1.1 Checking Outer Packing Materials

Packing materials and components may be damaged during transportation. Therefore, check the outer packing materials for damage, such as holes and cracks. If any damage is found, do not unpack the battery and contact the dealer as soon as possible. You are advised to remove the packing materials within 24 hours before installing the battery.

3.1.2 Cheeking Deliverables





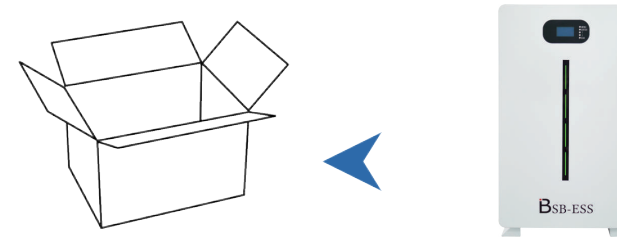





After unpacking the battery, check whether deliverables are intact and complete. If any damage is found or any component is missed, contact the dealer.

The below table shows the components and mechanical parts that should be delivered.



NO	Picture	Quan ty	Descrip on
1		1PCS	Battery
2		1PCS	Fixed bracket
3		1PCS	Positive power cord
4		1PCS	Negative power cord
5		1PCS	485 Communication cable
6		1PCS	CAN Communication cable
7		1PCS	Shipment report
8		1PCS	Manual
9		1PCS	Certificate
10		1PCS	Label

3.2 Tools

Model	Tools		
Installation	 Knife	 Measuring tape	 Socket wrench (10/16mm)
	 Rubber mallet	 Cross Screwdriver	 Percussion drill (12mm)
Protection	 ESD gloves	 Safety goggles	 Anti-dust respirator
	 Safety shoes		

3.3 Installation requirements

3.3.1 Installation environment requirements

- *Install the battery in the indoor environment.
- *Place battery in secure location away from children and animals.
- *Do not place the battery near any heat sources and avoid sparks.
- *Do not expose the battery to moisture or liquids.
- *Do not expose the battery to direct sunlight.

3.3.2 Installation carrier requirements

- *Only mount battery on fire resistant building. Do not install batteries on flammable buildings.
- *Battery is quite heavy, make sure the wall/ground can meet the load bearing requirements.

STEP 1

Connect power cable

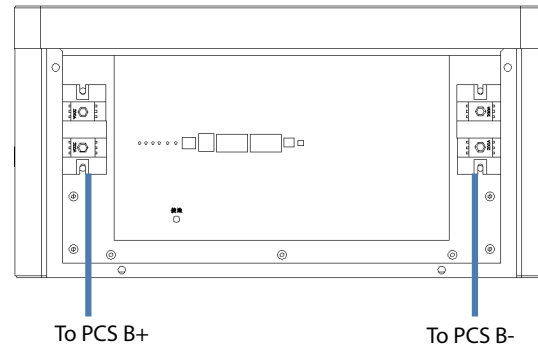

STEP 2

Connect communication cable

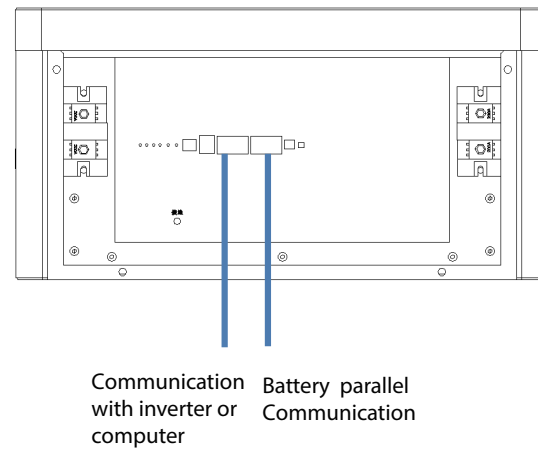

STEP 3

When multiple batteries are connected in parallel, follow the following wiring mode.

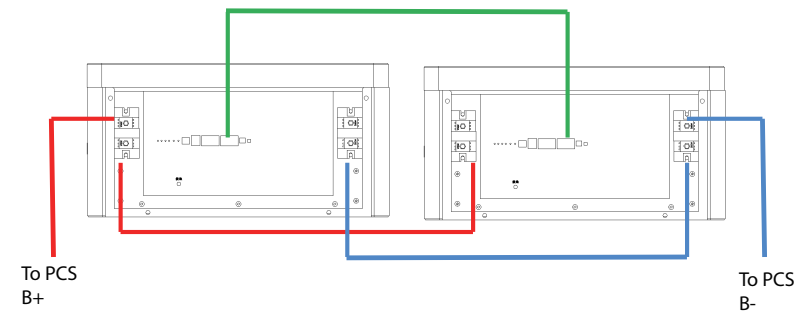

STEP 4

DIP Switch settings



When the pack is used in parallel, Different packages can be distinguished by setting the address through the dial switch on the BMS, To avoid setting addresses to the same, Refer to the table below for the definition of BMS dial switch.

address	Dial switch position			
	#1	#2	#3	#4
1	ON	OFF	OFF	OFF
2	OFF	ON	OFF	OFF
3	ON	ON	OFF	OFF
4	OFF	OFF	ON	OFF
5	ON	OFF	ON	OFF
6	OFF	ON	ON	OFF
7	ON	ON	ON	OFF
8	OFF	OFF	OFF	ON
9	ON	OFF	OFF	ON
10	OFF	ON	OFF	ON
11	ON	ON	OFF	ON
12	OFF	OFF	ON	ON
13	ON	OFF	ON	ON
14	OFF	ON	ON	ON
15	ON	ON	ON	ON

04

MAINTENANCE

4.1 Recharge Requirements During Normal Storage

Battery should be stored in an environment with temperature range between -10°C~+45°C, and maintained regularly according to following table with 0.5C(25A) current till 40% SOC after long storage time.

Recharge Requirements During Normal Storage

Storage Environment Temperature	Relative Humidity of Storage Environment	Storage Time	SOC
Below-10°C	/	prohibit	/
-10~25 °C	5%~70%	≤12 months	30% ≤SOC≤60%
25~35 °C	5%~70%	≤6 months	30% ≤SOC≤60%
35~45 °C	5%~70%	≤3 months	30% ≤SOC≤60%
Above45°C	/	prohibit	/

4.2 Recharge Requirements When Over Discharged

Over discharged (90%DOD) battery should be recharged according to following table, otherwise over discharged battery will be dam-

Recharge Requirements During Normal Storage

Storage Environment Temperature	Storage Time	Note
-10~25 °C	≤15 days	Battery Pack disconnected from PCS
-25~35 °C	≤7 days	
-35~45 °C	≤12 hours	Battery Pack connected to PCS